

Thermal Over-load Protector SN-2 / SNAP

The SN-2 delivers the maximum protection in the smallest package at an excellent price. It's the most reliable on the market, backed by the leading innovators in protection technology.

Each SN-2 has a bimetal disc specifically manufactured for each rating. Each device is then calibrated and checked for opening temperature. This results in optimum snap-acting open and reset characteristics necessary to achieve consistent performance over the required cycle life. The SN-2 protector is our most popular product, and it is 4.7 mm thick with contact rating of up to 12 Amps.

Features

- Compact Design
- Current and Temperature Sensitive
- Quick and Accurate Action
- Sealed steel case suitable for impregnation
- Polyester heat shrink sleeve for good electrical insulation as well as good thermal conduction.

Applications

- Pump sets
- Electric Motors
- Transformers
- Solenoids
- Rechargeable Battery Packs
- Fluorescent Lighting Ballasts

Specifications:

Rated Voltage Rated Current	230VAC, 2A to 12A
Operating Cycles	10,000 cycles
Maximum Temperature	160°C
Operating Range	50°C - 160°C
Setting Tolerance	+/- 5-10%
Differential	15-40°C
Insulation type	HS: Polyester heat shrink sleeve PS: Polyester sleeve
Lead wire type	X: XLPE T: PTFE S: Silicon P: PVC
Lead Wire Length	50mm, 70mm, 100mm 200mm

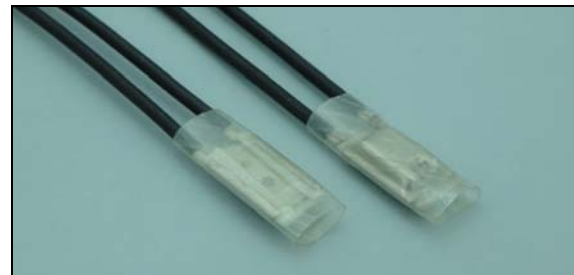

Selection code:

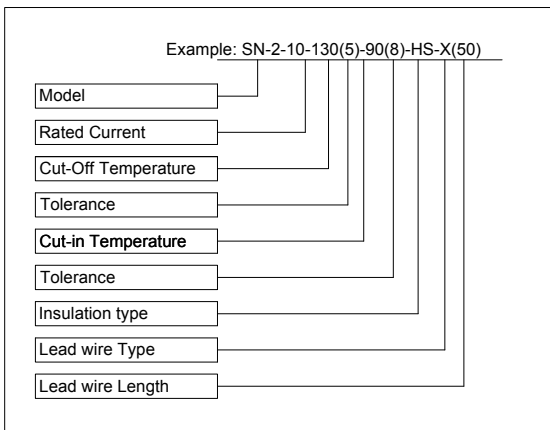

Operation

The operating principle of the SN-2 is both simple and effective. At the heart of the protector is a bimetal snap-action disc. When the temperature of this disc reaches its pre-calibrated temperature it snaps open, resulting in an open circuit. This temperature is reached during a fault condition. After the circuit breaks, the system cools and the SN-2 automatically resets, allowing power to be restored to the circuit.

Cut-section:

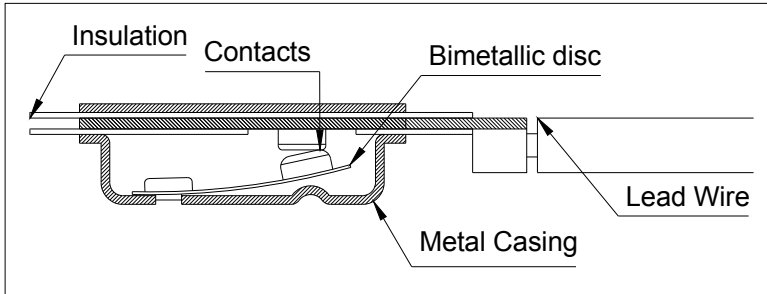

Line diagram:

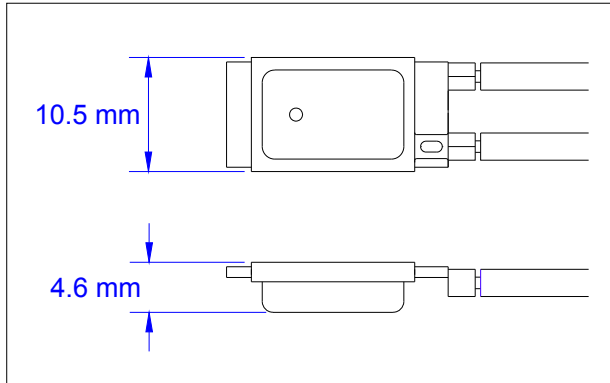

Characteristic Graph:

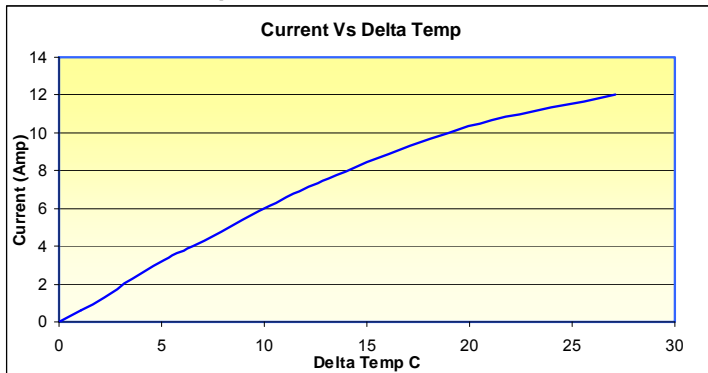

Note: Delta temp= Cut-off temp at No-load – Cut-off temp at rated Current

UTILITI CONTROLS

9, Mercantile, Above HSBC Bank, Gidwani Road, Chembur, Mumbai 400 074, INDIA.
Phone: 91-22-2520-6836 • Fax: 91-22-2520-0109
E-mail: utilt@mtnl.net.in, utiliticontrols@gmail.com

These instructions do not purport to cover all the details or variations in the equipment described, nor do they provide for every possible contingency to be met in connection with installation, operation and maintenance. All specifications are subject to change without notice. www.utiliticontrols.com
Should further information be desired or should particular problems arise which are not covered sufficiently for the purchaser's purposes, the matter should be referred to Utiliti Controls, Mumbai.