

Miniature Thermostat SN-9

The Miniature series of bimetal temperature controls offers proven reliability in a compact, versatile, cost-effective design. The snap-action of the bimetal disc provides high-speed contact separation resulting in excellent life cycle characteristics at electrical loads up to 8 amps at 230VAC (100,000 cycles). The quality, reliability, affordability, versatility of the Miniature Series makes it the thermostat of choice for a wide variety of temperature control applications.

Features

- Snap action disc
- High thermal sensitivity
- Low cost
- Long contact life
- Compact, slim design
- Available with / without mounting bracket

Applications

- Electrical Heating Pads
- Electrical Blankets
- Wax Heaters
- Food Warmers
- Milk Bottle Warmers
- Heat sink protection
- Other Small Appliances

Specifications:

Rated Voltage	230VAC
Rated Current	2A to 8A
Operating Cycles	100,000 cycles
Maximum Temperature	160°C
Operating Range	50°C - 160°C
Setting Tolerance	+/- 5%
Differential	10 - 15°C
Terminals	Crimp Type
Mounting Bracket	M0, M1

TECHNICAL DATA SHEET



Selection Code:

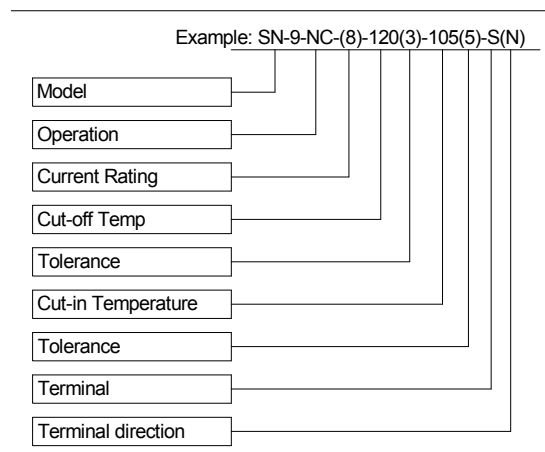

Line Diagram:

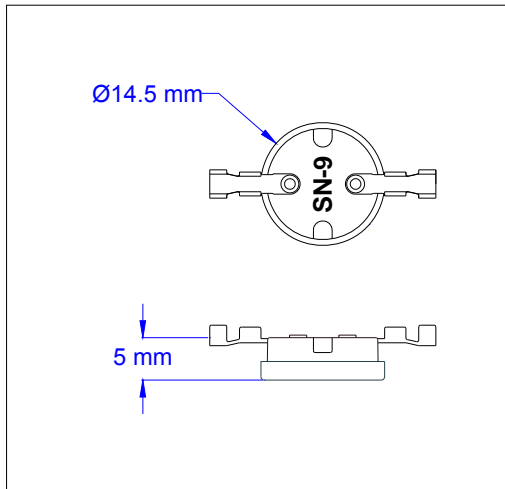

Mounting Bracket:

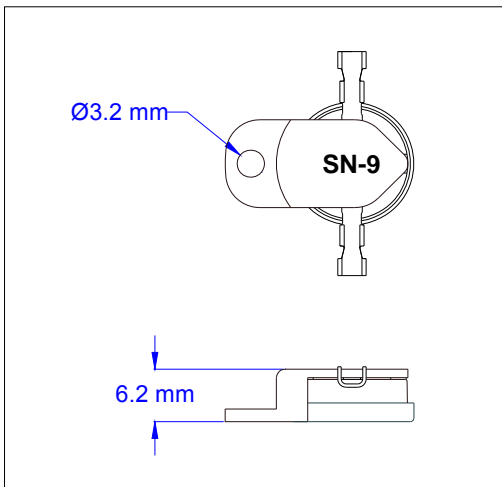

UTILITI CONTROLS

9, Mercantile, Above HSBC Bank, Gidwani Road, Chembur, Mumbai 400 074, INDIA.
Phone: 91-22-2520-6836 • Fax: 91-22-2520-0109
E-mail: utt@mtnl.net.in, utiliticontrols@gmail.com

These instructions do not purport to cover all the details or variations in the equipment described, nor do they provide for every possible contingency to be met in connection with installation, operation and maintenance. All specifications are subject to change without notice. www.utiliticontrols.com
Should further information be desired or should particular problems arise which are not covered sufficiently for the purchaser's purposes, the matter should be referred to Utiliti Controls, Mumbai